

Installation Manual

For Thermal Transfer Barcode Printer
GI-PLUS Series

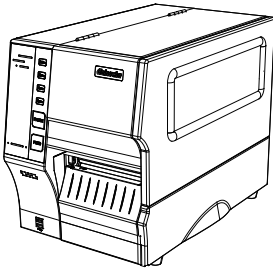

Please read this user guide before printer operation and keep this guide for reference.

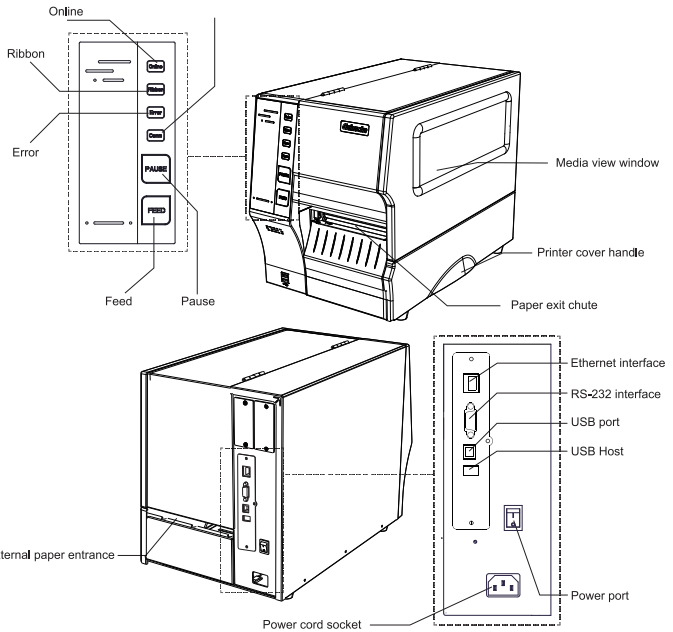

Note: The interface of printer showed in picture may have some differences from the model you purchased. As for the actual interface, please refer to the product specifications

Print media loading

<p>1. Move the label roll guard horizontally to the end of label spindle, then flip down the label roll guard.</p>	<p>2. Place the media roll on the label supply spindle and use label roll guard to fix it.</p>	<p>3. Pull the Print head release lever to open print head mechanism.</p>
<p>4. Install the label through the media guide bar, damper, media sensor, and label guide to install the media. (See the "Media Loading Path" illustration below).</p>	<p>5. Move the media sensor by adjusting the media sensor position adjustment knob, make sure the gap or black mark sensor is at the location where media gap/black mark will pass through for sensing. Adjust the label guide to fix the media position.</p>	<p>6. Close the print head mechanism on both sides and make sure the latches are engaged securely. Set media sensor type and calibrate the selected sensor.</p>



P/N:1.27.00.00315

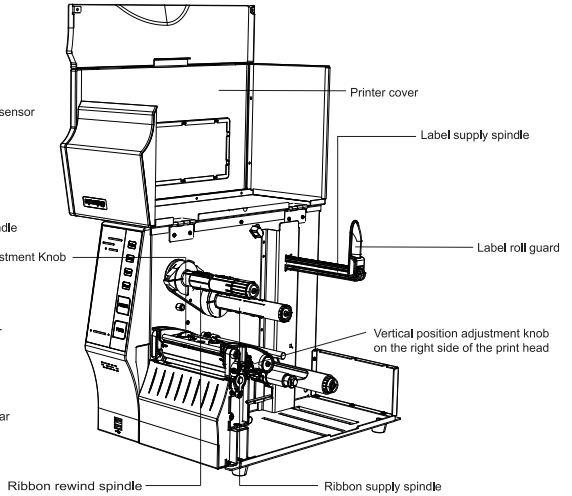
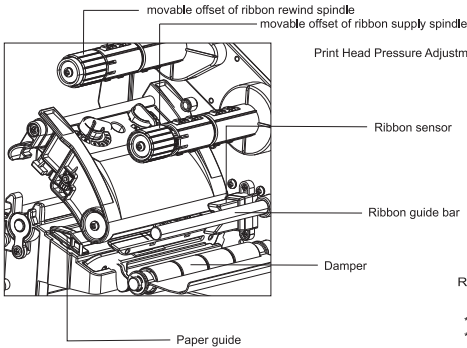
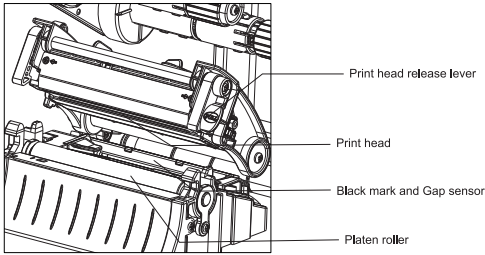

*If you need more information about the product, please refer to the User's Manual in CD.
*The printer specification, accessory, spare parts and program are subject to change without prior notice.

Ribbon loading

1. Lift the printer cover handle, and install the ribbon and empty ribbon roll on the ribbon supply spindle and ribbon rewind spindle, respectively.	2. Pull the movable offsets of the ribbon supply spindle and ribbon rewind spindle.	3. Pull the Print head release lever to open print head mechanism.	4. Thread ribbon below the ribbon sensor and through ribbon loading slot. (See the "Ribbon Loading Path" illustration below).

5. Fix the smooth and wrinkled front end of the ribbon on the empty ribbon roll.	6. Wind the ribbon rewind spindle clockwise roughly 3-5 circles until the ribbon is smooth, properly stretched and wrinkle-free.	7. Close the print head mechanism by pushing down the both sides of the print head release lever.

Ribbon and print media loading diagram

